



晶采光電科技股份有限公司  
AMPIRE CO., LTD.

# Specifications for LCD module

<b>Customer</b>	
<b>Customer part no.</b>	
<b>Ampire part no.</b>	<b>AM-1024600D3TZQW-TA6H-A</b>
<b>Approved by</b>	
<b>Date</b>	

Preliminary Specification

Formal Specification

**AMPIRE CO., LTD.**

**4F., No.116, Sec. 1, Xintai 5th Rd., Xizhi Dist., New Taipei City 221, Taiwan (R.O.C.)**

**新北市汐止區新台五路一段 116 號 4 樓(東方科學園區 A 棟)**

**TEL:886-2-26967269 , FAX:886-2-26967196 or 26967270**

<b>Approved by</b>	<b>Checked by</b>	<b>Organized by</b>
Patrick	Mark	Tank

\*This specification is subject to change without notice.

## RECORD OF REVISION

Revision Date	Page	Contents	Editor
2022/02/09	-	New release	Tank

## 1. Features

It's a 7 inches Amorphous-TFT-LCD (Thin Film Transistor Liquid Crystal Display) module. This module is composed of a 7" TFT-LCD panel, LED backlight.

- (1) Construction: 7" a-Si TFT active matrix, White LED Backlight.
- (2) Resolution (pixel): 1024 RGB (H) x 600 (V)
- (3) Number of the Colors : 16.7M colors ( R , G , B 8 bit digital each)
- (4) LCD type : Normally Black
- (5) Interface: LVDS
- (6) [New LED Driver TPS61185](#)

## 2. Physical Specifications

Item	Specifications	unit
LCD Size	7 inch (Diagonal)	
Resolution	1024 x (RGB) x 600	dot
Pixel Pitch	0.1506(W) x 0.1432(H)	mm
Active Area	154.2144(W) x 85.92(H)	mm
Module Size	164.9(W) x 100.0(H) x 11.2(D)	mm
Color Arrangement	RGB-stripe	

### 3. Absolute Maximum Ratings

Item	Symbol	Values			Unit	Remark
		MIN	TYP	MAX		
Power Voltage	VDD	-0.3	--	4	V	
LED Driver Power Voltage	VLED	-0.3	--	19	V	
Operation Temperature	TOP	-20	-	70	°C	
Storage Temperature	TST	-30	-	80	°C	

Note(1) The absolute maximum rating values of this product are not allowed to be exceeded at any times. Should a module be used with any of the absolute maximum ratings exceeded, the characteristics of the module may not be recovered, or in an extreme case, the module may be permanently destroyed.

#### 4. Backlight Driving Conditions

ITEM	SYMBOL	MIN	TYP	MAX	UNIT	NOTE
LED Driver Power Voltage	VLED	--	12	19	V	
LED Driver Power Current	ILED(VLED=12V)	--	363	--	mA	Ta=25°C
PWM Dimming DC active level	VDIMH	2.1	--	6	V	
	VDIML	0	--	0.8	V	
PWM Dimming Freq.	FDIM	0.2	--	20	kHz	
BLEN Pin High Voltage	VBLENH	2.1	--	6	V	
BLEN Pin Low Voltage	VBLENL	0	--	0.8	V	
LED voltage	VAK	--	26.4	--	V	Note 1
LED current	IF	--	132	--	mA	Note 1
LED life time	--	--	50	--	kHrs	Note 2

Note(1) The LED Supply Voltage is defined by the number of LED at Ta=25°C and IF=132 mA.

Note(2) The “LED life time” is defined as the module brightness decrease to 50% original brightness at Ta=25°C and IF=132mA. The LED lifetime could be decreased if operating IF is larger than 132mA.

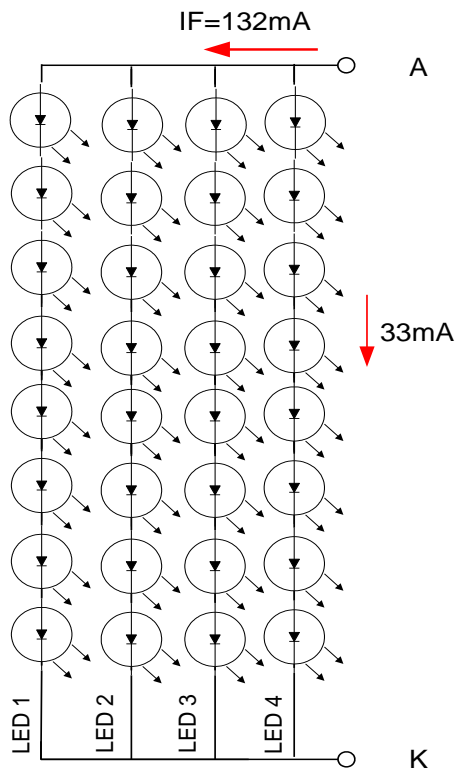

Note(1) When LCM is operated over 40°C ambient temperature, the IF should be follow :

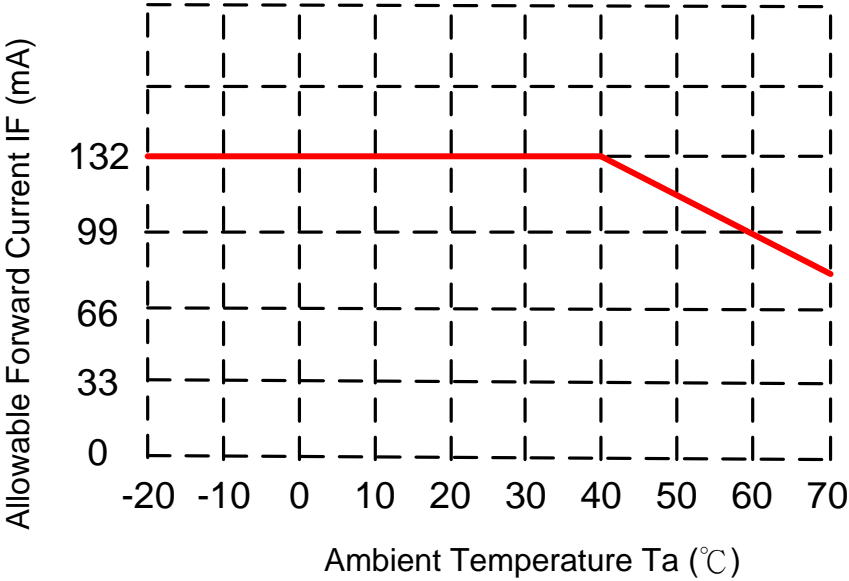

## 5. Optical Specifications

Item	Symbol	Condition	Values			Unit	Note
			Min.	Typ.	Max.		
Viewing angle (CR ≥ 10)	$\theta L$	$\Phi = 180^\circ$ (9 o'clock)	80	85	--	degree	Note1
	$\theta R$	$\Phi = 0^\circ$ (3 o'clock)	80	85	--		
	$\theta T$	$\Phi = 90^\circ$ (12 o'clock)	80	85	--		
	$\theta B$	$\Phi = 270^\circ$ (6 o'clock)	80	85	--		
Response time	TON	Normal $\theta = \Phi = 0^\circ$	--	13	20	msec	Note3
	TOFF		--	15	25	msec	
Contrast ratio	CR		600	800	--	--	Note4
Color chromaticity	WX		0.26	0.31	0.36	--	Note5 Note6
	WY		0.31	0.36	0.41	--	
	RX		0.56	0.61	0.66		
	RY		0.29	0.34	0.39		
	GX		0.31	0.36	0.41		
	GY		0.52	0.57	0.62		
	BX		0.05	0.10	0.15		
	BY	0.03	0.08	0.13			
Luminance (central point)	L	<b>640</b>	<b>800</b>	--	cd/m <sup>2</sup>	Note6	
Luminance uniformity	YU	70	75	--	%	Note6	

Test Conditions:

VDD = 3.3V, IF = 132 mA (Backlight current), the ambient temperature is 25°C.

The test systems refer to Note 2.

Note(1) Definition of viewing angle range

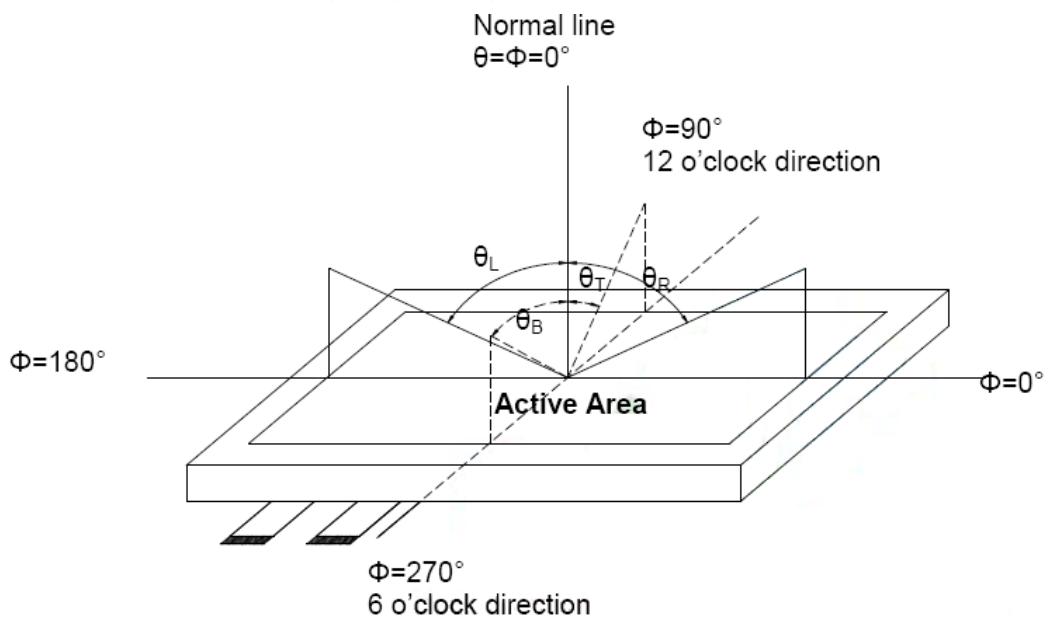

Note(2) Definition of optical measurement system

The optical characteristics should be measured in dark room. After 30 minutes operation, the optical properties are measured at the center point of the LCD screen. (Response time is measured by Photo detector TOPCON BM-7, other items are measured by BM-5A/Field of view:  $1^\circ$  / Height: 500mm.)

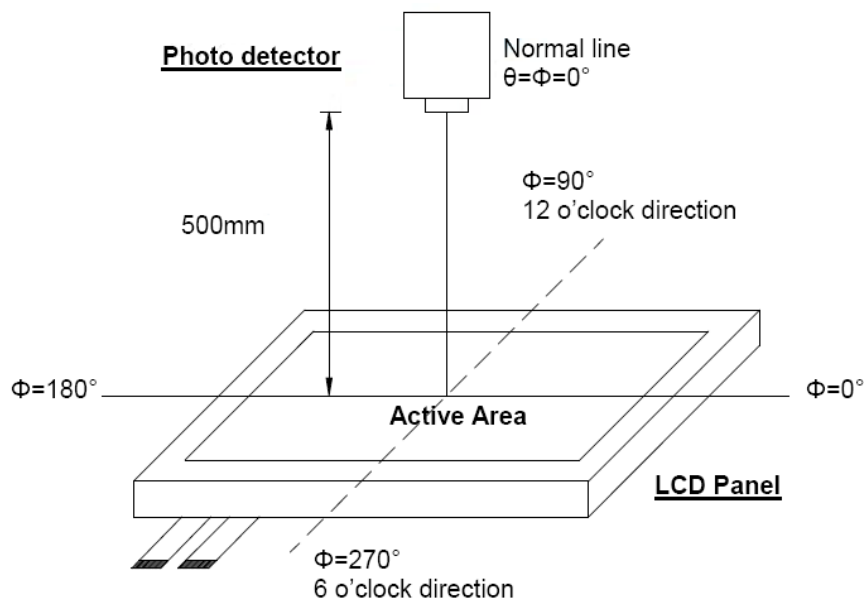



Note(3) Definition of Response time

The response time is defined as the LCD optical switching time interval between “White” state and “Black” state. Rise time (TON) is the time between photo detector output intensity changed from 90% to 10%. And fall time (TOFF) is the time between photo detector output intensity changed from 10% to 90%.

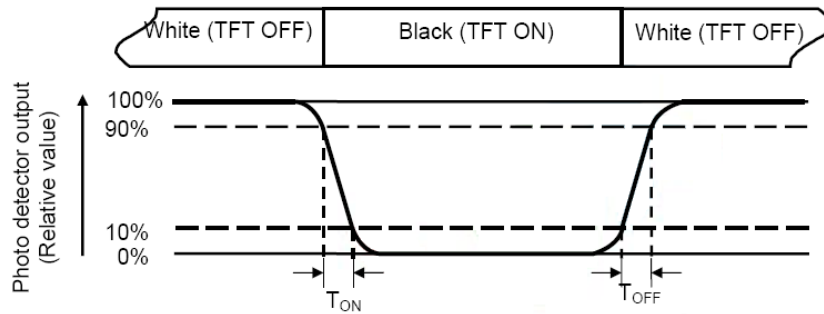

Note(4) Definition of contrast ratio

$$\text{Contrast ratio (CR)} = \frac{\text{Luminance measured when LCD on the "White" state}}{\text{Luminance measured when LCD on the "Black" state}}$$

Note(5) Definition of color chromaticity (CIE1931)

Color coordinated measured at center point of LCD.  
All input terminals LCD panel must be ground when measuring the center area of the panel.

Note(6) Definition of Luminance Uniformity

Active area is divided into 9 measuring areas (Refer to bellow figure).  
Every measuring point is placed at the center of each measuring area.

$$\text{Luminance Uniformity (Yu)} = \frac{B_{\min}}{B_{\max}}$$

L ----- Active area length      W ----- Active area width

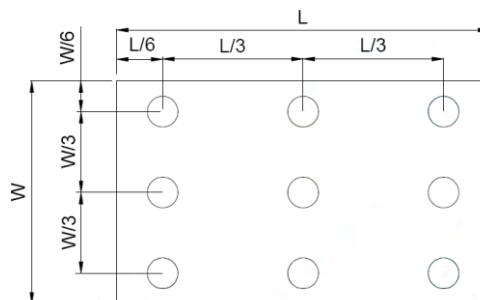

Bmax: The measured maximum luminance of all measurement position.  
Bmin: The measured minimum luminance of all measurement position.

Note(7) Pixel format

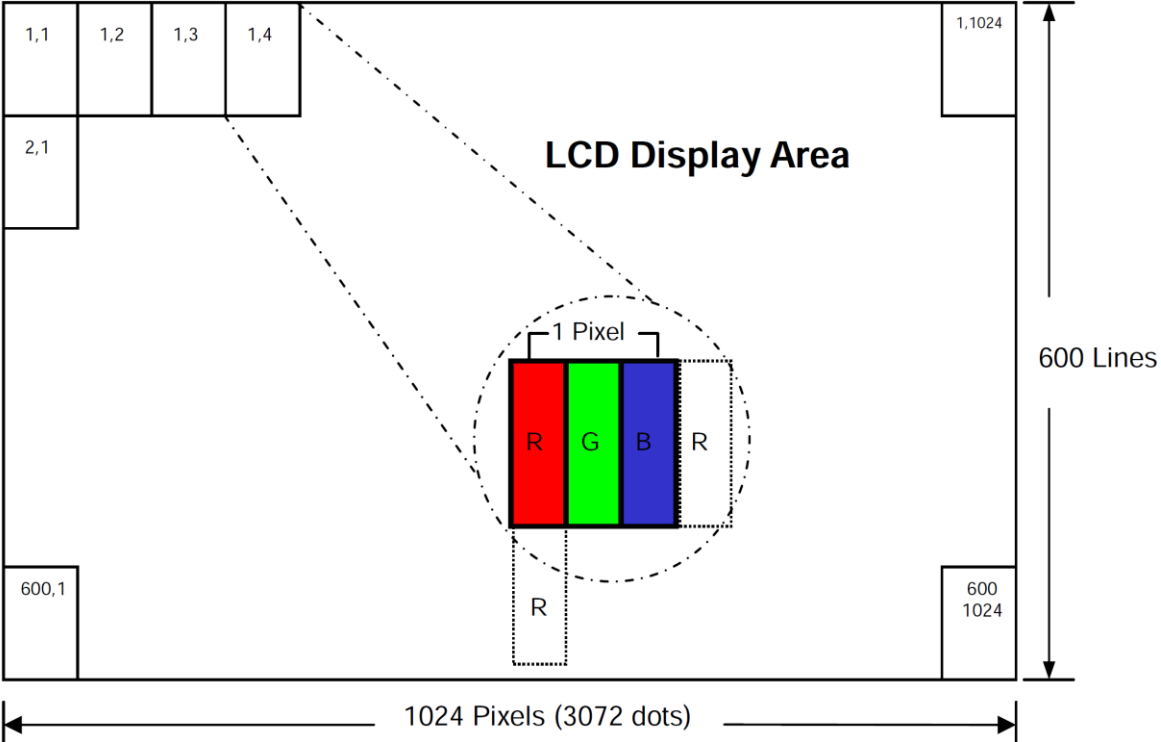

## 6. Interface

CN2:P1.0 20Pin/CP100-S20G-H16 or Equivalent

Pin No.	Symbol	Function
1	VDD	POWER SUPPLY
2	VDD	POWER SUPPLY
3	GND	Power Ground
4	GND	Power Ground
5	IN0-	Transmission Data of Pixels
6	IN0+	Transmission Data of Pixels
7	GND	Power Ground
8	IN1-	Transmission Data of Pixels 1
9	IN1+	Transmission Data of Pixels 1
10	GND	Power Ground
11	IN2-	Transmission Data of Pixels 2
12	IN2+	Transmission Data of Pixels 2
13	GND	Power Ground
14	CLK-	Sampling Clock
15	CLK+	Sampling Clock
16	GND	Power Ground
17	IN3-	Transmission Data of Pixels 3
18	IN3+	Transmission Data of Pixels 3
19	GND	Power Ground
20	GND	Power Ground

I: input, O: output, P: power

CN3: ENTERY 3808K-F05N-03L or Equivalent, Mating Connector: ENTERY H208K-P05N-02B or Equivalent

1	VLED	Power supply of LED driving circuit
2	GND	Power Ground
3	BLEN	LED BLU ON/OFF, High: enable, Low: disable
4	DIM	Adjust the LED brightness by PWM
5	NC	No connection

Note(1) BLU means Backlight Unit

## 7. Electrical Characteristics

### 7.1 DC Characteristics

Item	Symbol	Min.	Typ.	Max.	Unit	Condition
Digital Power Supply Voltage	VDD	3.0	3.3	3.6	V	
Digital Power Supply Current	IDD		55		mA	
Differential Input High Threshold	VTH	--	--	100	mV	VCM=1.2V
Differential Input Low Threshold	VTL	-100	--	--	mV	
Input current	IIN	-10	--	+10	uA	
Differential input Voltage	VID	0.2	--	0.6	V	
Common Mode Voltage Offset	VCM	$\frac{ VID }{2}$	1.25	$2.4 - \frac{ VID }{2}$	V	

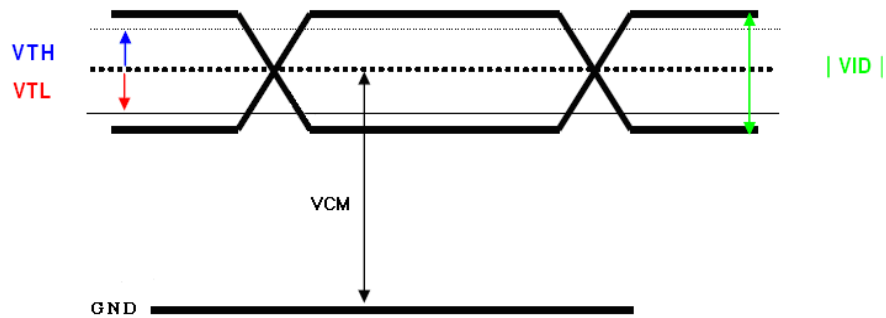

## 7.2 AC Characteristics

### TTL

DE mode					
Parameter	Symbol	Spec.			Unit
		Min.	Typ.	Max.	
DCLK frequency	fclk	40.8	51.2	67.2	MHz
Horizontal display area	thd		1024		DCLK
HSD period	th	1114	1344	1400	DCLK
HSD blanking	thb+ thfp	90	320	376	DCLK
Vertical display area	tvd		600		TH
VSD period	tvbp	610	635	800	TH
VSD blanking	tvbp+ tvfp	10	35	200	TH
HV mode					
DCLK frequency	fclk	44.9	51.2	63	MHz
Horizontal display area	thd		1024		DCLK
HSD period	th	1200	1344	1400	DCLK
HSD pulse Width	thpw	1	-	140	DCLK
HSD back porch	thbp		160		DCLK
HSD front porch	thfp	16	160	216	DCLK
Vertical display area	tvd		600		TH
VSD period	tv	624	635	750	TH
VSD pulse Width	tvpw	1	-	20	TH
VSD back porch	tvbp		23		TH
VSD front porch	tvfp	1	12	127	TH

### Horizontal timing

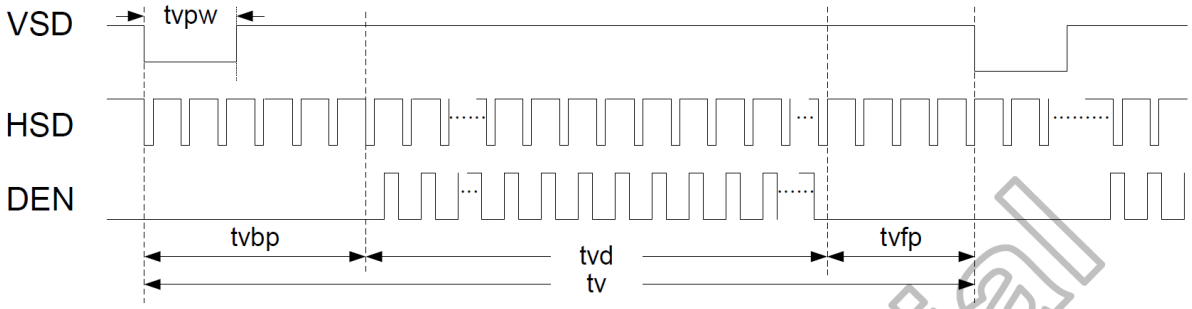

### Vertical timing

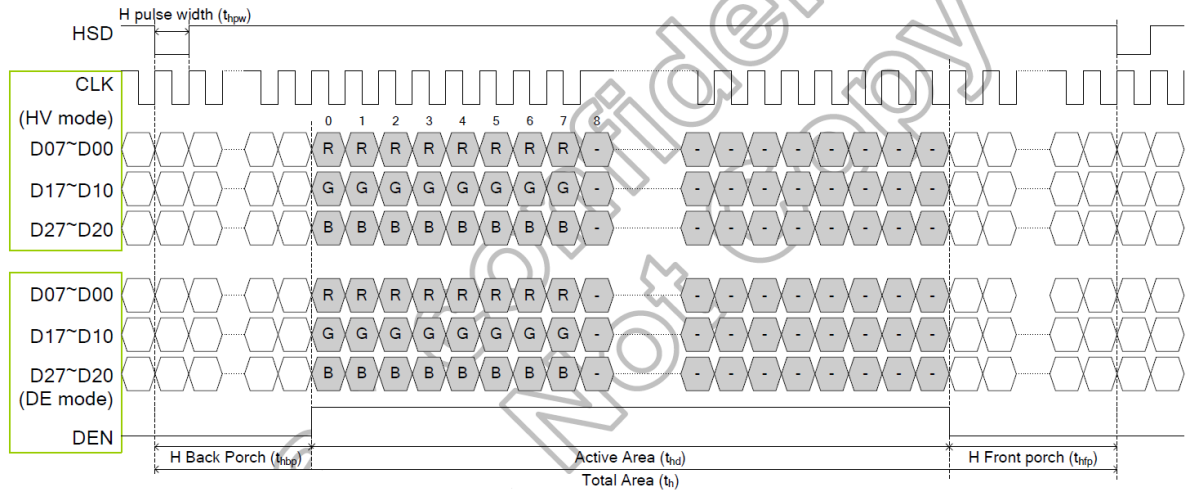

### 7.3 Power ON/OFF sequence

VDD power and LED on/off sequence are as follows. Interface signals are also shown in the chart. Signal shall be Hi-Z state or low level when VDD is off.

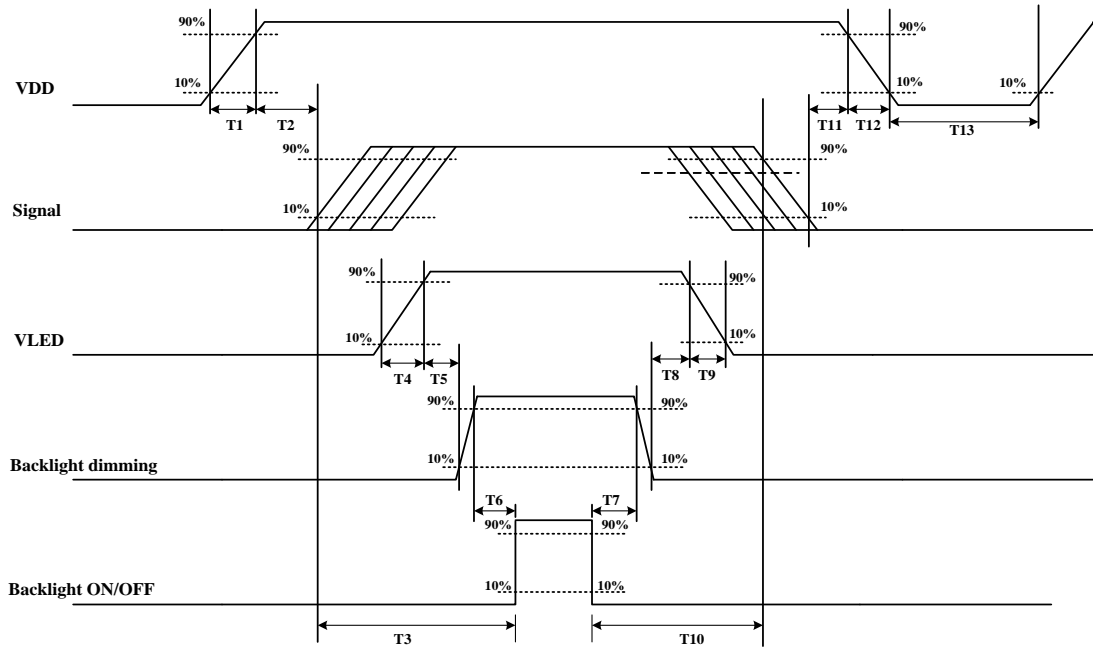

Parameter	Value			Units
	Min.	Typ.	Max.	
T1	0.5	-	10	[ms]
T2	0	40	50	[ms]
T3	200	-	-	[ms]
T4	0.5	-	10	[ms]
T5	10	-	-	[ms]
T6	10	-	-	[ms]
T7	0	-	-	[ms]
T8	10	-	-	[ms]
T9	-	-	10	[ms]
T10	110	-	-	[ms]
T11	0.5	16	50	[ms]
T12	-	-	100	[ms]
T13	1000	-	-	[ms]

## 7.4 24-BIT LVDS Input Data Format

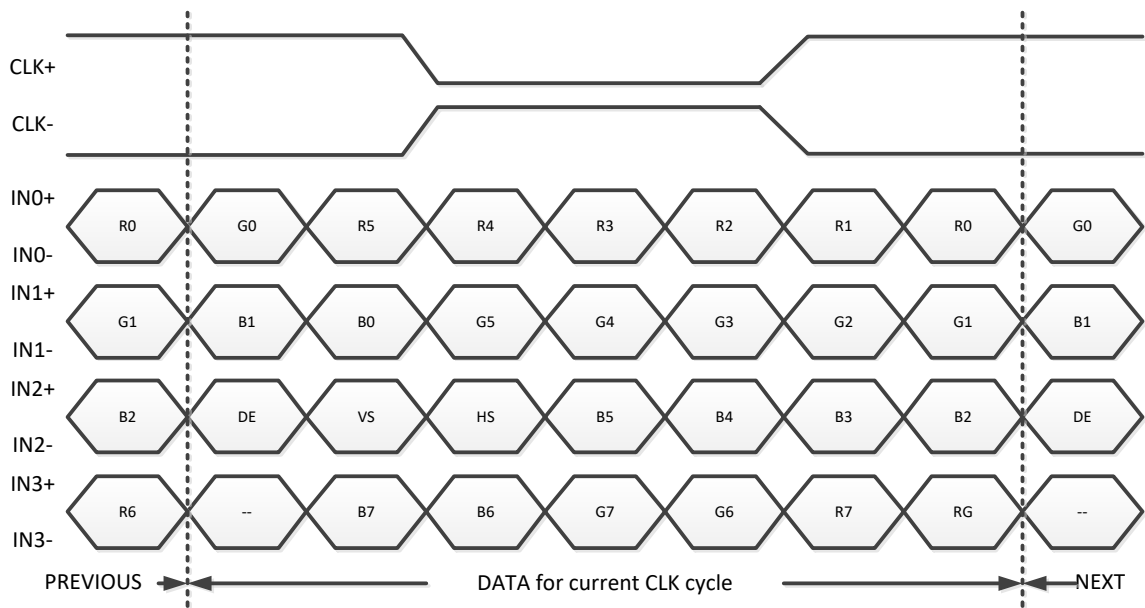

Note: R/G/B data 7: MSB, R/G/B data 0: LSB

Signal Name	Description	Remark
R7 R6 R5 R4 R3 R2 R1 R0	Red Data 7 (MSB) Red Data 6 Red Data 5 Red Data 4 Red Data 3 Red Data 2 Red Data 1 Red Data 0 (LSB)	Red-pixel Data Each red pixel's brightness data consists of these 8 bits pixel data.
G7 G6 G5 G4 G3 G2 G1 G0	Green Date 7 (MSB) Green Date 6 Green Date 5 Green Date 4 Green Date 3 Green Date 2 Green Date 1 Green Date 0 (LSB)	
B7 B6 B5 B4 B3 B2 B1 B0	Blue Data 7 (MSB) Blue Data 6 Blue Data 5 Blue Data 4 Blue Data 3 Blue Data 2 Blue Data 1 Blue Data 0 (LSB)	
CLK+ CLK-	LVDS Clock Input	
DE	Display Enable	
VS	Vertical Sync Signal	
HS	Horizontal Sync Signal	



## 8. Touch Panel Electrical Specification

Parameter	Condition	Standard Value
Terminal Resistance	X Axis	400 ~ 1150 $\Omega$
	Y Axis	100 ~ 500 $\Omega$
Insulating Resistance	DC 25 V	More than 20M $\Omega$
Linearity	--	$\leq 1.5 \%$
Notes life by Pen	Note a	100,000 times(min)
Input life by finger	Note b	1,000,000 times (min)

### Interface

No.	Symbol	Function
1	XL	Touch Panel Left Signal in X Axis
2	YB	Touch Panel Bottom Signal in Y Axis
3	XR	Touch Panel Right Signal in X Axis
4	YT	Touch Panel Top Signal in Y Axis

## 9. Reliability Test Conditions

Test Item	Test Conditions	Note
High Temperature Operation	70±3°C , t=240 hrs	
Low Temperature Operation	-20±3°C , t=240 hrs	
High Temperature Storage	80±3°C , t=240 hrs	1,2
Low Temperature Storage	-30±3°C , t=240 hrs	1,2
Storage at High Temperature and Humidity	60°C, 90% RH , 240 hrs	1,2
Thermal Shock Test	-20°C (30min.) ~ 25°C(5min.) ~ 70°C (30min.) 100 cycles	1,2
Vibration Test (Packing)	Sweep frequency : 10 ~ 55 ~ 10 Hz/1min Amplitude : 0.75mm Test direction : X.Y.Z/3 axis Duration : 30min/each axis	2

Note(1) Condensation of water is not permitted on the module.

Note(2) The module should be inspected after 1 hour storage in normal conditions (15-35°C, 45-65%RH).

Note(3) The module shouldn't be tested over one condition, and all the tests are independent.

Note(4) All reliability tests should be done without the protective film.

Definitions of life end point :

- Current drain should be smaller than the specific value.
- Function of the module should be maintained.
- Appearance and display quality should not have degraded noticeably.
- Contrast ratio should be greater than 50% of the initial value.

## **10. General Precautions**

### **10.1 Safety**

- (1) Liquid crystal is poisonous. Do not put it your mouth. If the liquid crystal touches you skin or clothes, you need to wash it off immediately with the soap and water.

### **10.2 Handling**

- (1) The LCD panel is plate glass. Do not subject the panel to mechanical shock or excessive force on its surface.
- (2) The polarizer which attached to the display is easily damaged. Please handle it carefully to avoid scratch or other damages.
- (3) To avoid contamination on the display surface, do not touch the module surface with bare hands.
- (4) Keep a space so that the LCD panels do not touch other components.
- (5) Put on cover board such as acrylic board, which covers on the surface of LCD panel to protect panel from damages.
- (6) Transparent electrodes may be disconnected if you use the LCD panel under environmental conditions where the condensation of dew occurs.
- (7) Do not leave module in direct sunlight to avoid malfunction of the ICs.

### **10.3 Mechanism**

- (1) Please mount LCD module by using mounting holes arranged in four corners tightly.

### **10.4 Static Electricity**

- (1) Be sure to ground module before you turn on power or operation module.
- (2) Do not apply voltage which exceeds the absolute maximum rating value.

### **10.5 Storage**

- (1) Store the module in a dark room where it must keep at  $+25\pm 10^{\circ}\text{C}$  and 65%RH or less.
- (2) Do not store the module in surroundings which are containing organic solvent or corrosive gas.
- (3) Store the module in an anti-electrostatic container or bag.

### **10.6 Cleaning**

- (1) Do not wipe the polarizer with dry cloth. It might cause scratch.
- (2) Only use a soft sloth with IPA to wipe the polarizer, other chemicals might permanent damage to the polarizer.

### **10.7 Others**

- (1) AMIPRE will provide one year warrantee for all products and three months warrantee for all repairing products.
- (2) Do not keep the LCD at the same display pattern continually. The residual image will happen and it will damage the LCD. Please use screen saver.

# 11. Outline Dimension

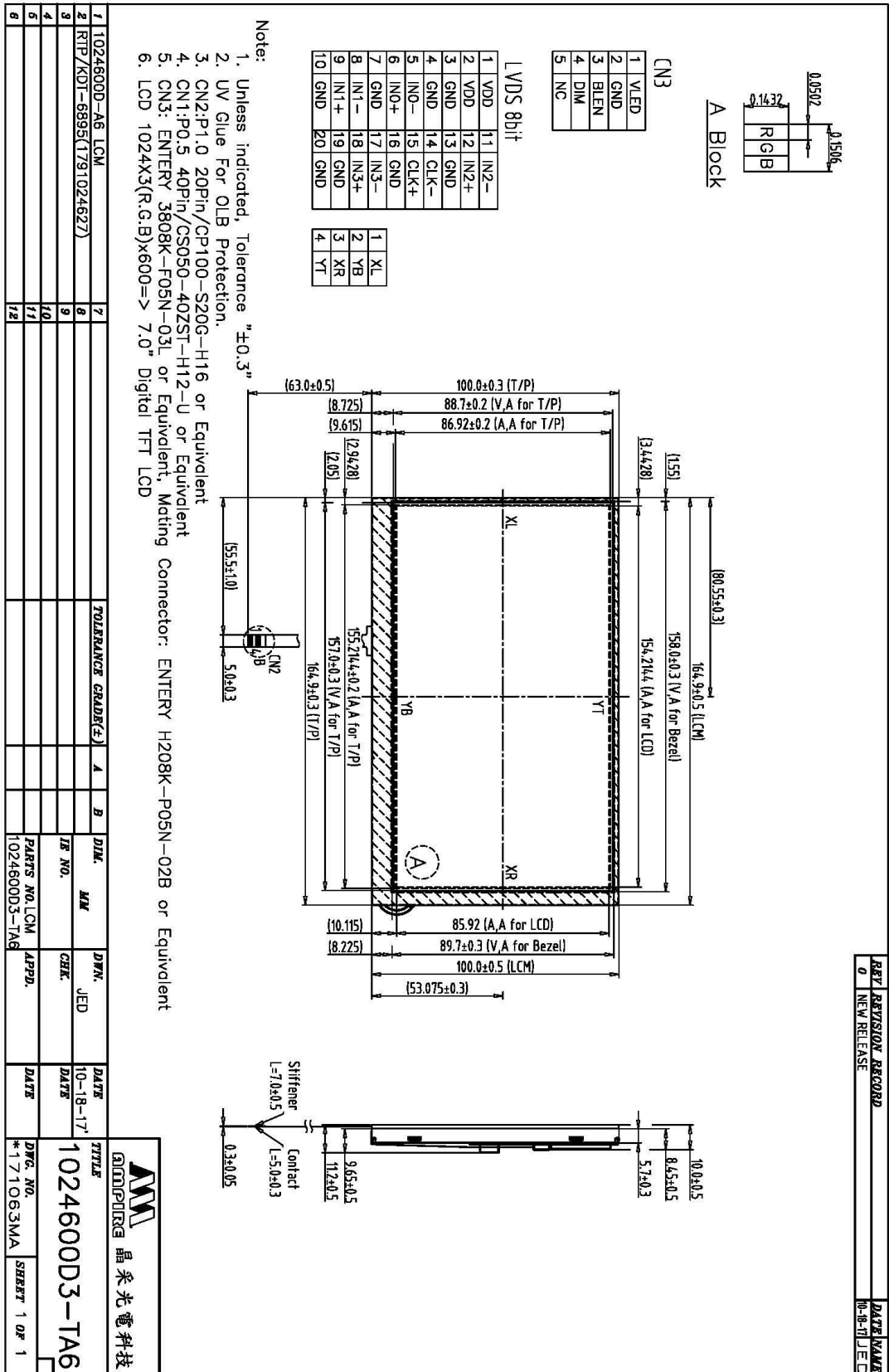

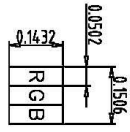

A Block

CN3

1	VLED
2	GND
3	BLEN
4	DIM
5	NC

L VDS 8bit

1	VDD	11	IN2-
2	VDD	12	IN2+
3	GND	13	GND
4	GND	14	CLK-
5	IND-	15	CLK+
6	IND+	16	GND
7	GND	17	IN3-
8	IN1-	18	IN3+
9	IN1+	19	GND
10	GND	20	GND

1	XL
2	YB
3	XR
4	YT

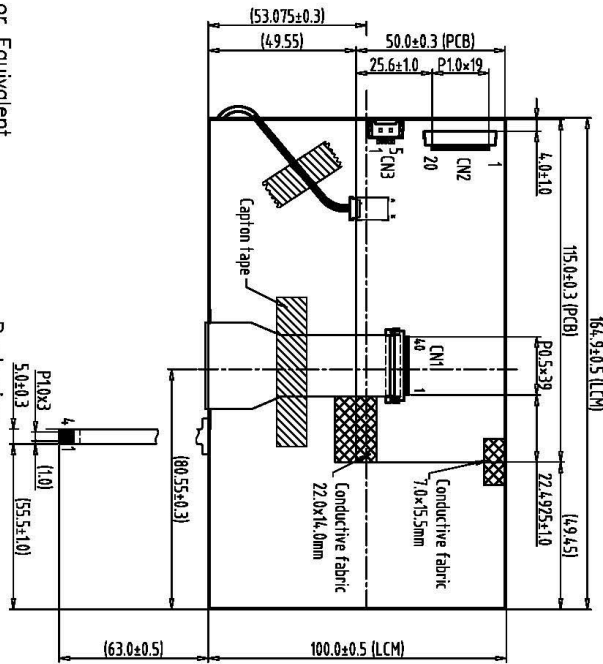

Back View

- Note:
1. Unless indicated, Tolerance "±0.3"
  2. UV Glue For OLB Protection.
  3. CN2:P10.20Pfn/CP100-S20G-H16 or Equivalent
  4. CN1:P0.5 40Pfn/CS050-40ZST-H12-U or Equivalent
  5. CN3: ENTERY 3808K-F05N-03L or Equivalent; Mating Connector: ENTERY H208K-F05N-02B or Equivalent
  6. LCD 1024X3(R,G,B)x600=> 7.0" Digital TFT LCD

1	1024600D-A6 LCM	7		TOLERANCE GRABER(Z)	A	B	DIM.	MM	DWN.	JED	DATE	10-18-17	TITLE	1024600D3-TA6	DWG. NO.	*171064MA	SHEET	1 OF 1
2	RTP/KDT-6895(1791024627)	8									DATE							
3		9																
4		10																
6		11																
8		12																

